

Compressors, Chillers & Condensers

CARLYLE OPEN DRIVE COMPRESSORS/ACCESSORIES DIRECT DRIVE UNIT BASES

- Heavy duty channeled steel base
- Coupling guard included
- Motor and compressor mounting holes are predrilled.

Select motor drilling code from the chart below:

MOTOR DRILLING CODE CHART

CODE	H. P.	FRAME	CODE	H.P.	FRAME	CODE	H. P.	FRAME
A	5	184T	F	25	284T	L	75	365T
B	7.5	213T	G	30	286T	M	100	404T
C	10	215T	H	40	324T	N	125	405T
D	15	254T	J	50	326T	O	150	444TS
E	20	256T	K	60	364T	P	200	445TS

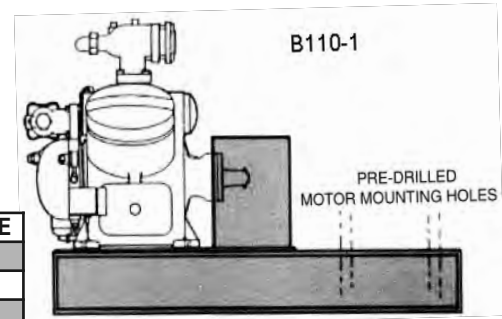

COMPRESSOR USED WITH	MOTOR DRILLING SELECTION	BASE SIZE (L x W x H)	APPROX BASE WEIGHT	DIRECT DRIVE UNIT BASE PART NO
5F20	A,B,C	37 x 16 x 11	200	5F20-515(*)
5F30	B,C,D	37 x 16 x 11	200	5F20-515(*)
5F40	B,C,D,E,F	48 x 22 x 6	250	5F40-398(*)
5F60	C,D,E,F,G	48 x 22 x 6	250	5F40-398(*)
5H40	E,F,G,H,J	56 x 25 x 8	400	5H40-588(*)
5H46	F,G,H,J,K	56 x 25 x 8	400	5H40-588(*)
5H60	G,H,J,K,L	56 x 25 x 8	400	5H40-588(*)
5H66	H,J,K,L,M†	56 x 25 x 8	400	5H40-588(*)
5H80	H,J,K,L,M	75 x 32 x 10	800	5H80-588(*)
5H86	J,K,Mt,Nt	75 x 32 x 10	800	5H80-588(*)
5H120	K,L,M,N,O	75 x 32 x 10	800	5H80-588(*)
5H126	L,M,N,O,P	75 x 32 x 10	800	5H80-588(*)

(*)Select motor drilling from chart above to complete part number. For example, when 5F20-515A is selected the base will be drilled to accept a 5 H.P., 184T frame motor. †5H66, 80, 86 with 100 H.P. motor and 5H86 with 125 H.P. motor require (2) 5H40-1422 compressor blocks.

NOTE: For base drilling code selections "H" thru "N", an "S" placed at the end of the part number indicates a base drilling for a short shaft Motor/TS frame.

(For example, Part No. 5H40-588HS is a 5H40-588 base drilled to accept a 324TS frame motor.)

BELT DRIVE UNIT BASES

- Heavy duty channeled steel base
- Belt guard included.
- Compressor mounting holes are predrilled.
- An adjustable steel motor base facilitates motor positioning.

Select adjustable motor base from the chart below:

ADJUSTABLE MOTOR BASE CODE CHART

CODE	H. P.	FRAME	CODE	H. P.	FRAME	CODE	H.P.	FRAME
A	5	184T	F	25	284T	L	75	365T
B	7.5	213T	G	30	286T	M	100	404T
C	10	215T	H	40	324T	N	125	405T
D	15	254T	J	50	326T			
E	20	256T	K	60	364T			

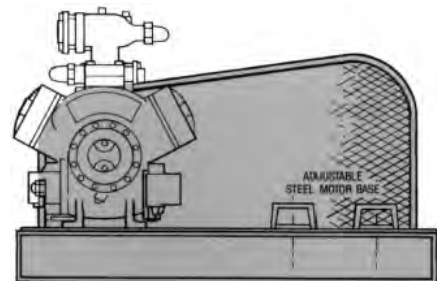

B111-1

COMPRESSOR USED WITH	ADJUSTABLE MOTOR BASE	BASE SIZE (L x W x H)	APPROX BASE WEIGHT	BELT DRIVE UNIT BASE PART NO
5F20	A, B,C	37 x 16 x 11	150	5F20-238(*)
5F30	B,C, D	37 x 16 x 11	150	5F20-238(*)
5F40	B,C,D,E,F	48 x 22 x 6	250	5F40-408(*)
5F60	C,D,E,F,G	48 x 22 x 6	250	5F40-408(*)
5H40	E,F,G,H,J	56 x 25 x 8	440	5H40-598(*)
5H60	G,H,J,K,L	56 x 25 x 8	440	5H40-598(*)
5H80	H,J,K,L,M	75 x 32 x 10	625	5H60-974(*)
5H120	K,L,M,N	75 x 32 x 10	625	5H60-974(*)

(*)Select adjustable base code from chart above to complete part number.

For example, when 5F20-238A is selected the adjustable motor base will accept a 5 H.P., 184T frame motor.