

TOTALINE® FG SERIES INLINE CENTRIFUGAL FANS



The Totaline® FG Series galvanized steel housing makes these fans ideal for various commercial code and residential applications. Home uses include range hood exhaust, duct boosting, bathroom exhaust and dryer boosting. Office applications include intake, exhaust, filtration, return or makeup air systems that require mounting versatility, high efficiency, low sound levels, and ease of service.

The FG Series fans are a snap to install. Prewired and supplied with a mounting bracket, they can be mounted at any angle in any point along the ductwork. Straight-through airflow design also helps simplify installation. FG Series fans are designed to work with standard dimensions of spiral duct, eliminating the need for transition pieces.

FEATURES:

- Galvanized steel housing features baked powder coat finish, perfect for commercial code applications.
- Powered by external rotor motorized impeller for excellent heat dissipation, even at low rpm.
- Tested and approved by UL and CSA (or equals).
- Suitable for airstream temperatures up to 140°F.
- 4-in. to 12-in. circular duct diameters.
- Airflow from 148-801 cfm.
- External rotor motor, Class B insulation for long, maintenance free operation.
- Automatic reset thermal overload protection.
- Permanently lubricated sealed ball bearings.
- True airfoil backward curved impeller.
- External wiring box for easy of connection.
- 100% speed controllable.

P451-FG4XL — 4-in. Duct — 148 CFM
 P451-FG5XL — 5-in. Duct — 191 CFM
 P451-FG6 — 6-in. Duct — 257 CFM
 P451-FG6XL — 6-in. Duct — 392 CFM

P451-FG8 — 8-in. Duct — 481 CFM
 P451-FG8XL — 8-in. Duct — 521 CFM
 P451-FG10XL — 10-in. Duct — 590 CFM
 P451-FG12XL — 12-in. Duct — 801 CFM

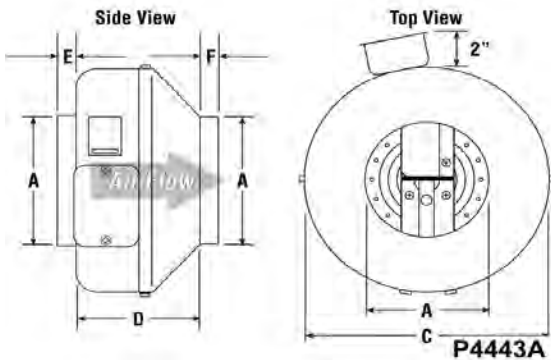

MODEL	A*	C	D	E	F
P451-FG4XL	4	9-1/2	5-1/2	7/8	3/4
P451-FG5XL	5	9-1/2	5	7/8	1
P451-FG6	6	11-1/2	6	3/4	7/8
P451-FG6XL	6	13-1/4	6-1/2	1	3/4
P451-FG8	8	13-1/4	6-1/4	1	7/8
P451-FG8XL	8	13-1/4	6-1/4	1	7/8
P451-FG10XL	10	13-1/4	6-1/4	1	1-1/4
P451-FG12XL	12	16	8-1/4	1	1-1/4

*Duct connections are 1/8-in. smaller than duct size.
 NOTE: All dimensions in inches.

STATIC PRESSURE (in wg)

Model	RPM	VOLTS	MAX WATTS	MAX AMPS	0	.125	.25	.375	.5	.75	1.0	1.25	1.5	MAX Ps (in)	DUCT DIA (in)
P451-FG4XL	2800	115	83	0.73	148	139	130	120	111	90	68	42	--	1.65	4
P451-FG5XL	2650	115	87	0.76	191	175	161	146	131	102	75	45	--	1.61	5
P451-FG6	2700	115	84	0.74	257	241	221	197	178	143	99	59	--	1.60	6
P451-FG6XL	2950	115	147	1.26	392	368	346	326	305	263	228	191	150	2.27	6
P451-FG8	2600	115	116	1.02	481	444	403	361	319	237	177	130	76	2.04	8
P451-FG8XL	2950	115	152	1.31	521	496	469	440	411	345	282	231	180	2.29	8
P451-FG10XL	3000	115	242	2.11	590	565	541	519	496	442	394	339	290	2.79	10
P451-FG12XL	3250	115	373	3.21	801	783	765	747	729	692	655	611	566	3.69	12