

HENRY TECHNOLOGIES - LIQUID REFRIGERANT RECEIVERS

S-8060 SERIES VERTICAL RECEIVERS

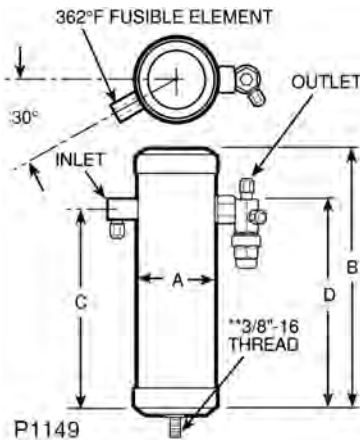

Receivers should be selected based on the operating charge for all system components, including the liquid lines. It is usual to add a small percentage to cover the refrigerant in long runs of suction and discharge lines, etc. It is essential that the maximum operating charge be determined, e.g., winter charge in air cooled condenser having flooded head pressure control, this being much greater than the normal summer charge.

S-8060 SERIES VERTICAL RECEIVERS

PART NO	*PUMP DOWN CAPACITY (lbs)			DIMENSIONS (in)				CONNECTIONS		WT(lb)
	R-134a	R-22	R404A/R-507	A	B	C	D	Inlet	Outlet	
S-8060	2.4	2.4	2.0	3.00	10	7	7	1/4 FLARE	1/4 FLARE	2
S-8061	2.4	2.4	2.1	3.50	7.5	5	5	1/4 FLARE	1/4 FLARE	2
S-8062	3.3	3.3	2.8	3.50	10	7.63	7.63	1/4 FLARE	1/4 FLARE	3
S-8063	4.3	4.2	3.7	4.00	10	7.25	7.25	1/4 FLARE	1/4 FLARE	4
S-8064	6.7	6.6	5.7	5.00	10	6.75	6.75	1/4 FLARE	1/4 FLARE	6
S-8065	11.6	11.5	10.0	6.00	12	8	8	3/8 FLARE	3/8 FLARE	10
S-8066	17.6	17.3	15.0	6.00	18	15	15	3/8 FLARE	1/2 FLARE	16
S-8067	23.5	23.2	20.1	6.00	24	21.25	14.88	1/2 FLARE	1/2 FLARE	21
S-8068	29.4	29.1	25.2	6.00	30	27.25	14.88	5/8 FLARE	5/8 FLARE	26

Maximum WP 450 PS

*All Pump Down Capacities are calculated @ 90% of receiver volume @ 90° F.

S-8600 SERIES HORIZONTAL RECEIVERS

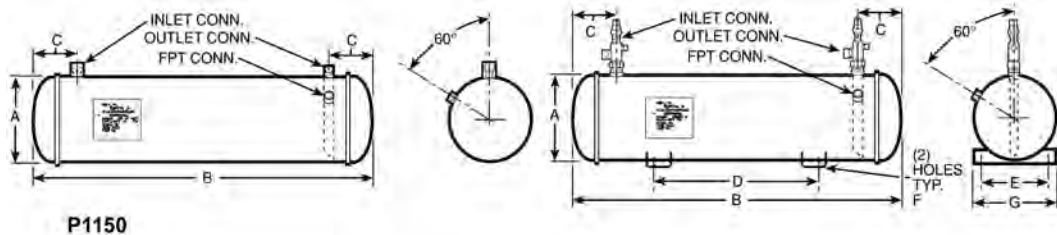

P1150

S-8600 SERIES HORIZONTAL RECEIVERS

PART NO	*PUMP DOWN CAPACITY (lbs)			DIMENSIONS (in)			CONNECTIONS			SHIP WEIGHT (lb)
	R-134a	R-22	R404A/R-507	A	B	C	Inlet	Outlet	FPT	
S-8600	18.8	18.6	16.2	5.00	28	3.00	5/8 ODS	5/8 ODS	3/8	19
S-8610	24.3	24.0	20.9	5.00	36	3.00	5/8 ODS	5/8 ODS	3/8	25
S-8620	29.2	28.8	25.0	6.00	30	3.63	5/8 ODS	5/8 ODS	3/8	24
S-8630	35.0	34.6	30.1	6.00	36	3.63	5/8 ODS	5/8 ODS	3/8	28

S-8600V SERIES HORIZONTAL RECEIVERS WITH BRACKETS & VALVES

PART NO	*PUMP DOWN CAPACITY (lbs)			DIMENSIONS (in)						CONNECTIONS			SHIP WEIGHT (lb)	
	R-134a	R-22	R404A/R-507	A	B	C	D	E	F	G	Inlet	Outlet		FPT
S-8600V	18.8	18.6	16.2	5.00	28	3.00	14	5.50	.44	7.00	1/2 ODS	1/2 ODS	3/8	19
S-8630V	35.0	34.6	30.1	6.00	36	3.63	18	5.50	.44	7.00	1/2 ODS	1/2 ODS	3/8	28

*Pump Down Capacities are calculated @ 90% of receiver volume @ 90° F.

HENRY TECHNOLOGIES - LIQUID REFRIGERANT RECEIVER ACCESSORIES

LIQUID LEVEL GAUGES



P1165

PART NO	RECEIVER DIA
S-9450	8-5/8
S-9451	10-3/4
S-9452	12-3/4
S-9453	14
S-9454	16
S-9455	18
S-9456	20

Mating flanges for level gauges not included on most receivers.

BRACKET KITS

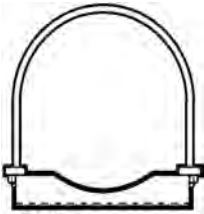

P1166

PART NO	RECEIVER DIA
3-019-908	8-5/8
3-019-910	10-3/4
3-019-912	12-3/4

NOTE: Designed for horizontal mounting use only.

ROTO-LOC VALVES

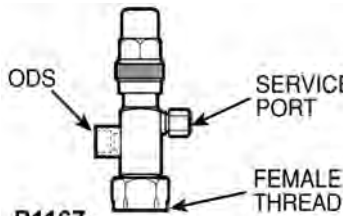

P1167

Includes gasket.

PART NO	THREAD	ODS
3-030-140	1" - 14	1/2
3-030-141	1-1/4" - 12	7/8
3-030-142	1-1/4" - 12	1-1/8
3-030-143	1-3/4" - 12	1-3/8
3-030-150	1" - 14	5/8

ROTO-LOC/ODS ADAPTERS

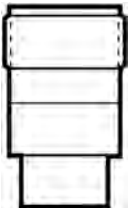

P1168

PART NO	THREAD	ODS
2-009-037	1" - 14	5/8
3-009-308	1-1/4" - 12	7/8
2-009-046	1-3/4" - 12	1-3/8

Compressors,
Chillers, Condensers

Motors

Electrical

Heating
Components

Indoor Air
Quality

Thermostats

Oils &
Chemicals

Accessories, Supplies
& Commodities

Tools &
Instruments

Refrigeration