

# COMPRESSORS, CHILLERS & CONDENSERS

## MARINE CONDENSER

### ACME MHX MARINE CONDENSER

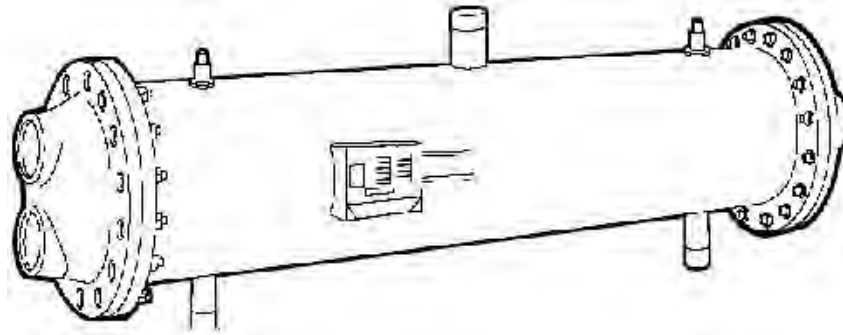

ACME® Type MHX condensers are manufactured with the latest technology marine condenser tubing to provide compact size and cost effective use.

#### STANDARD DESIGNS

ACME® MHX condensers are available in standard designs for sea water duty. Standard MHX water condensers are available from 5 to 330 nominal tons of duty and are manufactured in large quantities to provide the lowest cost per ton available. Non-standard marine condensers are available to meet virtually any chiller application.

#### MODERN TUBE MATERIALS

ACME® MHX condensers utilize the latest technology tubing. Years of research and development, combined with thorough testing in our own labs have resulted in the highest efficiency condensers available. All condensers are manufactured with 3/4" diameters 90/10 cupro-nickel tubing to provide heavy wall construction and ease of service from commonly available tube cleaning devices.

#### MODIFICATIONS

ACME® refrigeration heat exchangers are available with special materials of construction as required. Fresh water condensers can be made from stainless steel for increased life with poor quality cooling water. Vessels can be equipped with cupro-nickel tubes and tube sheets or titanium tubes for sea water duty. If your application calls for something special, just ask.

- **Shells** – Steel pipe to ASME specification. Shells are shot blasted and cleaned prior to assembly.
- **Tubes** – 90/10 cupro-nickel high performance enhanced design roller expanded into grooved tube sheets.
- **Tube sheet** – 90/10 cupro-nickel to ASME specifications. Precision machined for excellent sealing.
- **Tube Supports** – Quality steel manufactured to close tolerance to minimize vibration.
- **Heads** – Cast bronze to withstand the corrosive effects of sea water duty. Single-pass 14" & 16" heads are fabricated from steel and epoxy coated.
- **Connections** – All water side connections are FPT except 12" 1-pass, 14" and 16" models which have flanges. Refrigerant connections are steel and bored to ODS of copper tubing. Relief, vent and drain connections are provided.
- **Codes** – The refrigerant side is constructed to the latest edition of the ASME Section VIII Div 1 code and stamped. Refrigerant side is dual-rated for 450 psi at 150°F or 305 psi at 250°F. Water side design pressure is 150°F at 150 psi. Shell side is tested at 1.1 times and tube side is tested 1.3 times the design pressure.
- **Finish** – Exterior surfaces are cleaned and painted with an enamel primer.

# COMPRESSORS, CHILLERS & CONDENSERS

## MARINE CONDENSER

### ACME MHX MARINE CONDENSER

90/10 Cupro-Nickel  
 Tubes & Tube sheets  
 Bronze or Epoxy  
 Coated Heads

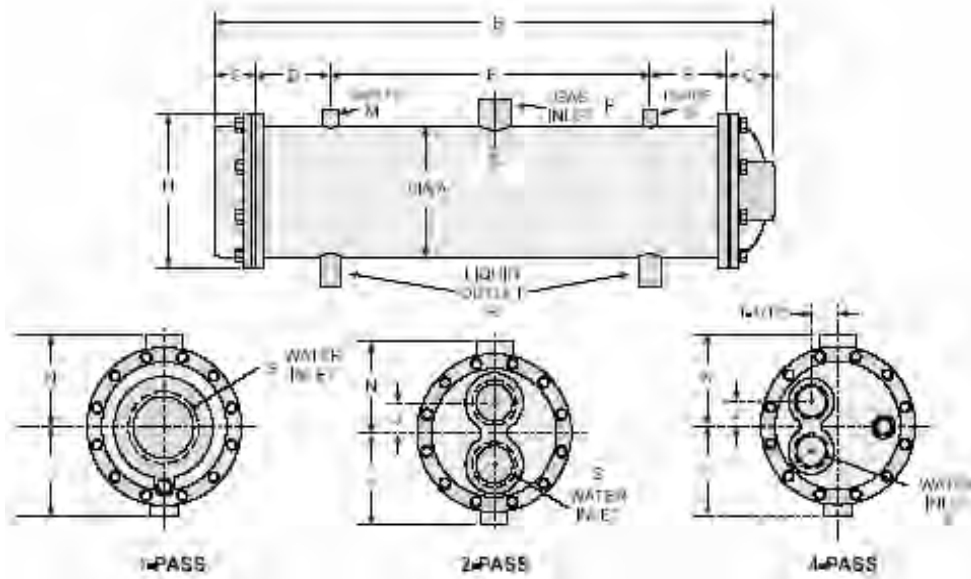

### CAPACITIES AND DIMENSIONS

MODEL MHE	NOM TON	A DIA	B LENGTH	C	D	E	F	G FPT	H	J	L	M FPT	N	PODF	R ODF	S NPT	PUMP DOWN	WGT LBS
MHX-602D-4	7.5	6-5/8	27-13/16	2-1/32	5-7/8	12	5-7/8	1/2	7-1/2	1-7/16	6-5/16	1/2	6-5/16	1-3/8	5/8	1-1/2	16	107
MHX-604B-4	5	6-5/8	21-7/8	2-1/32	5-7/8	12	5-7/8	1/2	7-1/2	1-7/16	6-5/16	1/2	6-5/16	1-3/8	5/8	1-1/2	28	180
MHX-603D-4	15	6-5/8	39-13/16	2-1/32	5-7/8	24	5-7/8	1/2	7-1/2	1-7/16	6-5/16	1/2	6-5/16	1-3/8	7/8	1-1/2	21	142
MHX-604D-4	20	6-5/8	51-13/16	2-1/32	5-7/8	36	5-7/8	1/2	7-1/2	1-7/16	6-5/16	1/2	6-5/16	1-3/8	7/8	1-1/2	28	175
MHX-605D-2	25	6-5/8	63-13/16	2-1/32	5-7/8	48	5-7/8	1/2	7-1/2	1-1/2	6-5/16	1/2	6-5/16	1-5/8	7/8	2	36	210
MHX-606D-2	30	6-5/8	75-13/16	2-1/32	5-7/8	60	5-7/8	1/2	7-1/2	1-1/2	6-5/16	1/2	6-5/16	1-5/8	1-1/8	2	43	244
MHX-805A-2	35	8-5/8	66	3-1/8	7-7/8	44	7-7/8	1/2	9-11/16	1-7/8	7-5/16	1/2	7-5/16	2-1/8	1-1/8	2-1/2	70	310
MHX-806A-2	45	8-5/8	78	3-1/8	7-7/8	56	7-7/8	1/2	9-11/16	1-7/8	7-5/16	1/2	7-5/16	2-1/8	1-1/8	2-1/2	84	357
MHX-808A-2	60	8-5/8	102	3-1/8	7-7/8	80	7-7/8	1/2	9-11/16	1-7/8	7-5/16	1/2	7-5/16	2-1/8	1-1/8	2-1/2	313	455
MHX-1005A-2	50	10-3/4	69	4-11/16	7-7/8	44	7-7/8	1/2	13-3/4	2-1/4	8-3/8	3/4	8-3/8	2-1/8	1-5/8	3	111	480
MHX-1006A-2	65	10-3/4	81	4-11/16	7-7/8	56	7-7/8	1/2	13-3/4	2-1/4	8-3/8	3/4	8-3/8	2-5/8	1-5/8	3	134	550
MHX-1008A-2	85	10-3/4	105-1/8	4-11/16	7-7/8	80	7-7/8	1/2	13-3/4	2-1/4	8-3/8	3/4	8-3/8	2-5/8	1-5/8	3	180	695
MHX-1205A-2	70	12-3/4	69	4-5/8	7-7/8	44	7-7/8	1/2	15-3/4	2-5/8	9-3/8	1	9-3/8	2-5/8	1-5/8	3	158	670
MHX-1206A-2	90	12-3/4	81	4-5/8	7-7/8	56	7-7/8	1/2	15-3/4	2-5/8	9-3/8	1	9-3/8	2-5/8	1-5/8	3	191	765
MHX-1208A-1	110	12-3/4	108	6-1/8	7-7/8	80	7-7/8	1/2	15-3/4	--	9-3/8	1	9-3/8	3-1/8	2-5/8	6‡	257	990
MHX-1208A-2	130	12-3/4	105	4-5/8	7-7/8	80	7-7/8	1/2	15-3/4	2-5/8	9-3/8	1	9-3/8	3-1/8	2-5/8	3	257	960
MHX-1210A-1	150	12-3/4	132	6-1/8	7-7/8	104	7-7/8	1/2	15-3/4	--	9-3/8	1	9-3/8	3-1/8	2-5/8	6‡	323	1155
MHX-1405B-2	130	14	69	5-1/8	7-7/8	44	7-7/8	1/2	17-7/8	4-1/2	10	1	10	3-1/8	1-5/8	4‡	160	955
MHX-1406B-2	140	14	81	5-1/8	7-7/8	56	7-7/8	1/2	17-7/8	4-1/2	10	1	10	3-1/8	2-1/8	4‡	194	1100
MHX-1408B-2	200	14	105	5-1/8	7-7/8	80	7-7/8	1/2	17-7/8	4-1/2	10	1	10	3-1/8	2-1/8	4‡	261	1400
MHX-1410B-1	220	14	139-3/8	9-11/16	7-7/8	104	7-7/8	1/2	17-7/8	--	10	1	10	3-5/8	2-1/8	6	328	1740
MHX-1608B-1	230	16	120-1/2	12-3/8	7-7/8	80	7-7/8	1/2	19-7/8	--	11	1	11	3-5/8	2-1/8	8	328	1750
MHX-1608B-2	275	16	105	5-1/8	7-7/8	80	7-7/8	1/2	19-7/8	5	11	1	11	5-1/8	3-1/8	5‡	328	1780
MHX-1610B-1	330	16	144-1/2	12-3/8	7-7/8	104	7-7/8	1/2	19-7/8	--	11	1	11	5-1/8	3-1/8	8§	412	2095

‡ = 125 Lb. FF Flange, § = 150 Lb. RF Flange

Nominal capacity based on: 14,400 BTUH per ton  
 85°F condenser water  
 10°F range with R-22 service at 105°F condensing temp.

Comprehensive rating tables are available for R-22, R-134a and R-404a.

Pump-down capacity is based on 80% of free shell volume with R-22 at 90°F per ARI.

Capacity includes 0.00025 hr-ft<sup>2</sup>-°F/Btu additive fouling.

# COMPRESSORS, CHILLERS & CONDENSERS

## MARINE CONDENSER

### ACME MHX MARINE CONDENSER

#### CAPACITY & FLOW RATES

R-22 AT 105°F CONDENSING TEMP WITH .00025 TOTAL FOULING, STANDARD MODELS

MHX-602-B-4			TOTAL HEAT OF REJECTION AT SPECIFIED GTD				
GPM	ΔP	15° F GTD	20° F GTD	25° F GTD	30° F GTD	35° F GTD	40° F GTD
12	0.8	50,560	66,626	81,948	97,593	112,508	126,670
20	2.0	66,825	87,696	107,730	126,944	146,476	165,795
28	3.8	77,766	101,822	124,708	147,305	169,643	190,880
36	6.1	85,520	111,361	136,280	160,890	185,226	209,317
44	9.0	91,140	119,312	146,403	171,745	196,800	223,038

MHX-602-D-4			TOTAL HEAT OF REJECTION AT SPECIFIED GTD				
GPM	ΔP	15° F GTD	20° F GTD	25° F GTD	30° F GTD	35° F GTD	40° F GTD
20	1.2	78,720	103,367	126,701	150,686	173,390	195,808
30	2.5	96,607	126,441	155,862	184,923	211,918	238,587
40	4.3	109,214	143,355	175,832	207,905	238,385	268,521
50	6.6	119,083	155,068	191,346	224,040	259,517	291,464
60	9.3	126,340	165,095	201,400	238,223	274,658	306,827

MHX-603-D-4			TOTAL HEAT OF REJECTION AT SPECIFIED GTD				
GPM	ΔP	15° F GTD	20° F GTD	25° F GTD	30° F GTD	35° F GTD	40° F GTD
20	1.5	102,983	135,900	168,158	200,005	230,951	262,055
30	3.1	132,010	173,934	214,711	253,731	293,532	331,613
40	5.3	153,507	202,020	247,938	293,264	338,066	382,394
50	8.1	170,052	222,669	273,227	323,160	372,541	421,428
60	11.4	182,485	238,527	295,556	348,481	400,827	452,652

MHX-604-D-4			TOTAL HEAT OF REJECTION AT SPECIFIED GTD				
GPM	ΔP	15° F GTD	20° F GTD	25° F GTD	30° F GTD	35° F GTD	40° F GTD
15	1.0	95,096	125,897	156,457	186,626	216,721	246,442
25	2.7	139,443	184,108	228,181	271,618	314,547	356,667
35	5.0	173,192	228,380	281,866	334,655	386,832	438,456
45	7.9	199,783	262,021	323,403	384,060	444,081	501,583
55	11.5	220,750	289,284	356,904	422,437	488,593	551,433

MHX-605-D-2			TOTAL HEAT OF REJECTION AT SPECIFIED GTD				
GPM	ΔP	15° F GTD	20° F GTD	25° F GTD	30° F GTD	35° F GTD	40° F GTD
30	0.7	157,494	207,766	257,037	305,624	353,588	400,977
50	1.8	218,536	286,998	353,471	420,127	483,853	546,799
70	3.3	260,399	342,055	422,636	500,471	573,746	649,852
90	5.2	293,650	383,500	469,606	557,159	638,646	724,391
110	7.6	318,342	414,779	509,908	600,638	693,646	779,121

MHX-606-D-4			TOTAL HEAT OF REJECTION AT SPECIFIED GTD				
GPM	ΔP	15° F GTD	20° F GTD	25° F GTD	30° F GTD	35° F GTD	40° F GTD
30	0.8	172,201	227,603	282,261	336,204	389,417	441,939
50	2.0	244,144	321,521	397,086	471,664	545,360	618,251
70	3.7	297,126	389,405	480,402	570,297	657,614	743,984
90	5.9	335,097	440,092	543,725	643,869	738,219	836,228
110	8.5	367,002	481,408	591,304	696,828	804,233	904,378

GTD refers to the difference between the condensing temperature and the inlet water temperature.

# COMPRESSORS, CHILLERS & CONDENSERS

## MARINE CONDENSER

### ACME MHX MARINE CONDENSER

#### CAPACITY & FLOW RATES

#### R-22 AT 105°F CONDENSING TEMP WITH .00025 TOTAL FOULING, STANDARD MODELS

MHX-805-A-2		TOTAL HEAT OF REJECTION AT SPECIFIED GTD					
GPM	ΔP	15° F GTD	20° F GTD	25° F GTD	30° F GTD	35° F GTD	40° F GTD
50	0.9	249,925	328,949	407,492	483,645	558,788	633,002
75	1.9	320,218	421,353	519,530	614,799	708,870	801,845
100	3.2	371,999	488,650	603,766	714,959	819,637	928,360
125	4.8	414,926	540,920	665,167	787,913	902,239	1,022,379
150	6.7	445,131	583,150	714,968	845,183	969,526	1,097,021
175	9.0	473,587	616,221	756,928	890,652	1,022,879	1,153,756

MHX-806-A-2		TOTAL HEAT OF REJECTION AT SPECIFIED GTD					
GPM	ΔP	15° F GTD	20° F GTD	25° F GTD	30° F GTD	35° F GTD	40° F GTD
50	1.0	275,113	363,351	450,183	535,892	619,855	703,531
75	2.1	359,908	473,088	584,665	694,854	801,137	908,864
100	3.6	424,466	556,293	686,288	814,711	939,448	1,062,834
125	5.4	472,736	619,956	765,215	908,803	1,041,226	1,178,598
150	7.6	514,247	670,757	831,203	981,706	1,130,552	1,269,519
175	10.1	549,195	714,953	883,450	1,040,014	1,194,826	1,348,059

MHX-808-A-2		TOTAL HEAT OF REJECTION AT SPECIFIED GTD					
GPM	ΔP	15° F GTD	20° F GTD	25° F GTD	30° F GTD	35° F GTD	40° F GTD
40	0.8	259,592	344,395	427,997	511,705	593,226	675,860
60	1.7	357,202	472,291	585,824	698,276	809,362	919,204
80	2.9	437,612	577,396	714,751	850,868	985,522	1,117,411
100	4.4	504,942	665,206	822,042	976,917	1,128,593	1,278,582
120	6.1	561,765	739,048	909,767	1,082,625	1,249,229	1,414,041
140	8.1	608,184	799,040	987,383	1,173,603	1,351,843	1,528,174
160	10.4	651,529	852,808	1,051,343	1,247,568	1,434,131	1,626,415

MHX-1005-A-2		TOTAL HEAT OF REJECTION AT SPECIFIED GTD					
GPM	ΔP	15° F GTD	20° F GTD	25° F GTD	30° F GTD	35° F GTD	40° F GTD
80	1.0	390,865	514,867	635,941	755,372	873,321	989,905
110	1.8	474,969	624,349	771,711	912,511	1,051,505	1,188,844
140	2.8	542,127	709,175	873,887	1,036,578	1,193,888	1,349,455
170	4.1	595,655	777,466	956,751	1,133,860	1,304,351	1,472,995
200	5.5	639,572	836,834	1,025,794	1,212,420	1,391,201	1,568,021
230	7.1	671,013	881,069	1,081,654	1,279,842	1,475,926	1,656,249
260	9.0	705,845	918,470	1,128,195	1,335,456	1,540,565	1,735,715

MHX-1006-A-2		TOTAL HEAT OF REJECTION AT SPECIFIED GTD					
GPM	ΔP	15° F GTD	20° F GTD	25° F GTD	30° F GTD	35° F GTD	40° F GTD
80	1.1	431,633	569,721	705,354	839,857	971,394	1,101,292
110	2.0	531,412	700,221	866,804	1,029,625	1,186,757	1,341,899
140	3.2	612,681	804,445	990,694	1,177,509	1,356,232	1,532,877
170	4.6	679,512	886,714	1,094,941	1,300,749	1,496,037	1,689,135
200	6.2	730,974	961,529	1,184,002	1,393,373	1,610,762	1,815,363
230	8.0	779,794	1,021,033	1,252,812	1,481,772	1,708,253	1,932,515
260	10.0	818,554	1,065,666	1,316,760	1,550,175	1,795,994	2,009,348

GTD refers to the difference between the condensing temperature and the inlet water temperature.

# COMPRESSORS, CHILLERS & CONDENSERS

## MARINE CONDENSER

### ACME MHX MARINE CONDENSER

#### CAPACITY & FLOWRATES

#### R-22 AT 105°F CONDENSING TEMP WITH .00025 TOTAL FOULING, STANDARD MODELS

MHX-1008-A-2			TOTAL HEAT OF REJECTION AT SPECIFIED GTD				
GPM	ΔP	15° F GTD	20° F GTD	25° F GTD	30° F GTD	35° F GTD	40° F GTD
90	1.7	535,804	708,436	878,736	1,047,414	1,214,043	1,378,806
120	2.9	656,419	866,094	1,072,126	1,276,302	1,478,283	1,676,117
150	4.4	757,413	997,809	1,233,062	1,465,376	1,692,890	1,917,873
180	6.2	842,648	1,108,572	1,364,650	1,623,938	1,873,844	2,121,061
210	8.2	912,277	1,198,559	1,481,074	1,760,405	2,027,764	2,292,261
240	10.5	977,294	1,279,211	1,577,015	1,871,352	2,151,196	2,439,623

MHX-1205-A-2			TOTAL HEAT OF REJECTION AT SPECIFIED GTD				
GPM	ΔP	15° F GTD	20° F GTD	25° F GTD	30° F GTD	35° F GTD	40° F GTD
80	0.6	434,571	573,741	710,936	845,169	978,847	1,109,526
120	1.3	571,765	754,067	932,006	1,103,516	1,276,982	1,444,098
160	2.3	679,982	891,367	1,103,245	1,305,515	1,505,281	1,702,756
200	3.4	764,993	1,002,033	1,235,811	1,461,698	1,684,917	1,905,710
240	4.8	832,453	1,094,730	1,340,702	1,590,011	1,836,637	2,074,119

MHX-1206-A-2			TOTAL HEAT OF REJECTION AT SPECIFIED GTD				
GPM	ΔP	15° F GTD	20° F GTD	25° F GTD	30° F GTD	35° F GTD	40° F GTD
80	0.7	472,445	625,484	775,779	924,810	1,071,578	1,216,612
120	1.5	634,168	836,260	1,035,512	1,231,044	1,424,134	1,612,077
160	2.5	761,843	1,004,530	1,241,455	1,469,889	1,701,102	1,923,981
200	3.8	865,921	1,138,008	1,406,461	1,663,136	1,925,471	2,176,259
240	5.4	951,312	1,248,483	1,541,695	1,819,849	2,106,467	2,378,348

MHX-1208-A-2			TOTAL HEAT OF REJECTION AT SPECIFIED GTD				
GPM	ΔP	15° F GTD	20° F GTD	25° F GTD	30° F GTD	35° F GTD	40° F GTD
80	0.8	523,016	693,742	862,100	1,032,353	1,197,741	1,361,242
120	1.8	722,907	956,246	1,186,950	1,415,556	1,641,222	1,864,225
160	3.0	888,914	1,173,608	1,453,886	1,729,713	2,003,129	2,273,696
200	4.5	1,027,834	1,355,820	1,677,335	1,994,985	2,303,852	2,614,736
240	6.4	1,145,318	1,509,619	1,865,391	2,208,661	2,556,246	2,891,670

MHX-1208-A-1			TOTAL HEAT OF REJECTION AT SPECIFIED GTD				
GPM	ΔP	15° F GTD	20° F GTD	25° F GTD	30° F GTD	35° F GTD	40° F GTD
200	0.5	905,280	1,191,110	1,472,894	1,751,098	2,021,952	2,281,132
300	1.1	1,148,319	1,504,462	1,855,584	2,194,694	2,529,591	2,860,624
400	1.9	1,328,860	1,732,695	2,130,804	2,523,929	2,889,836	3,274,171
500	2.9	1,455,920	1,912,051	2,347,428	2,777,473	3,172,689	3,593,421
600	4.0	1,561,726	2,042,768	2,517,420	2,967,998	3,413,533	3,854,520
700	5.3	1,648,226	2,160,296	2,643,634	3,121,119	3,571,197	4,016,454

MHX-1210-A-1			TOTAL HEAT OF REJECTION AT SPECIFIED GTD				
GPM	ΔP	15° F GTD	20° F GTD	25° F GTD	30° F GTD	35° F GTD	40° F GTD
200	0.7	1,030,031	1,359,449	1,682,245	2,000,819	2,310,308	2,621,212
300	1.4	1,332,726	1,748,748	2,158,811	2,563,686	2,963,912	3,346,811
400	2.3	1,557,675	2,047,303	2,520,735	2,978,336	3,430,373	3,877,338
500	3.4	1,732,282	2,278,035	2,789,808	3,294,993	3,794,293	4,288,265
600	4.8	1,881,939	2,450,200	3,010,605	3,564,278	4,094,544	4,619,196
700	6.3	1,989,677	2,598,260	3,198,740	3,771,317	4,337,588	4,876,960

GTD refers to the difference between the condensing temperature and the inlet water temperature.

# COMPRESSORS, CHILLERS & CONDENSERS

## MARINE CONDENSER

### ACME MHX MARINE CONDENSER

#### CAPACITY & FLOWRATES

#### R-22 AT 105°F CONDENSING TEMP WITH .00025 TOTAL FOULING, STANDARD MODELS

MHX-1406-B-2			TOTAL HEAT OF REJECTION AT SPECIFIED GTD				
GPM	ΔP	15° F GTD	20° F GTD	25° F GTD	30° F GTD	35° F GTD	40° F GTD
150	0.9	844,265	1,115,290	1,382,501	1,646,349	1,906,442	2,161,663
225	2.0	1,111,799	1,466,553	1,810,259	2,149,316	2,484,226	2,815,353
300	3.4	1,317,364	1,735,679	2,142,548	2,531,849	2,929,133	3,309,228
375	5.1	1,481,903	1,944,822	2,401,628	2,834,825	3,262,818	3,704,980
450	7.1	1,613,300	2,114,104	2,608,302	3,072,895	3,556,204	4,010,453

MHX-1408-B-2			TOTAL HEAT OF REJECTION AT SPECIFIED GTD				
GPM	ΔP	15° F GTD	20° F GTD	25° F GTD	30° F GTD	35° F GTD	40° F GTD
150	1.1	948,750	1,256,947	1,560,851	1,863,828	2,162,891	2,458,387
225	2.4	1,286,854	1,700,402	2,108,041	2,510,253	2,907,315	3,299,741
300	4.1	1,559,979	2,057,068	2,547,705	3,029,294	3,497,968	3,968,908
375	6.1	1,783,975	2,345,473	2,899,375	3,440,257	3,981,802	4,504,254
450	8.6	1,970,847	2,586,912	3,185,472	3,786,115	4,361,224	4,930,105

MHX-1410-B-1			TOTAL HEAT OF REJECTION AT SPECIFIED GTD				
GPM	ΔP	15° F GTD	20° F GTD	25° F GTD	30° F GTD	35° F GTD	40° F GTD
400	1.2	1,883,138	2,478,733	3,066,118	3,646,320	4,205,116	4,756,982
500	1.8	2,154,505	2,832,020	3,479,107	4,139,047	4,769,550	5,392,658
600	2.5	2,372,868	3,114,623	3,846,417	4,540,181	5,225,288	5,932,772
700	3.3	2,557,658	3,364,904	4,143,675	4,876,246	5,636,721	6,351,976
800	4.2	2,721,493	3,563,935	4,373,270	5,172,413	5,962,519	6,744,479
900	5.3	2,876,649	3,738,465	4,588,115	5,453,018	6,257,171	7,052,584
1000	6.4	2,977,533	3,900,628	4,811,657	5,682,896	6,544,668	7,338,160

7,304,307			TOTAL HEAT OF REJECTION AT SPECIFIED GTD				
GPM	ΔP	15° F GTD	20° F GTD	25° F GTD	30° F GTD	35° F GTD	40° F GTD
200	1.0	1,278,131	1,694,417	2,107,411	2,514,915	2,917,480	3,319,375
300	2.1	1,745,944	2,307,603	2,861,485	3,408,633	3,949,446	4,484,482
400	3.5	2,125,899	2,805,477	3,469,349	4,124,366	4,771,609	5,411,831
500	5.3	2,439,704	3,211,795	3,966,012	4,710,841	5,447,417	6,176,567
600	7.4	2,702,814	3,553,387	4,381,184	5,198,898	6,007,783	6,783,500
700	9.9	2,929,201	3,841,633	4,742,009	4,742,009	5,616,246	6,448,586

MHX-1608-B-1			TOTAL HEAT OF REJECTION AT SPECIFIED GTD				
GPM	ΔP	15° F GTD	20° F GTD	25° F GTD	30° F GTD	35° F GTD	40° F GTD
600	1.0	2,398,955	3,145,751	3,867,785	4,594,629	5,283,449	5,963,632
800	1.7	2,774,164	3,648,947	4,469,013	5,299,920	6,121,492	6,867,130
1000	2.6	3,082,744	4,022,197	4,948,606	5,834,513	6,709,853	7,575,562
1200	3.6	3,325,458	4,317,691	5,332,128	6,261,945	7,254,062	8,162,880
1400	4.8	3,506,522	4,584,370	5,626,152	6,611,761	7,629,849	8,549,796
1600	6.2	3,664,708	4,768,331	5,856,876	6,932,625	7,945,949	8,948,775

MHX-1610-B-1			TOTAL HEAT OF REJECTION AT SPECIFIED GTD				
GPM	ΔP	15° F GTD	20° F GTD	25° F GTD	30° F GTD	35° F GTD	40° F GTD
600	1.2	2,768,593	3,636,353	4,491,697	5,336,207	6,159,148	6,972,468
800	2.0	3,257,808	4,266,168	5,260,240	6,241,936	7,212,611	8,133,921
1000	3.1	3,643,228	4,767,579	5,876,502	6,945,772	8,029,306	9,048,047
1200	4.3	3,943,105	5,182,805	6,373,212	7,549,381	8,644,687	9,796,210
1400	5.7	4,223,696	5,521,123	6,760,535	7,984,712	9,195,424	10,394,057
1600	7.3	4,437,197	5,760,396	7,113,280	8,354,352	9,678,506	10,892,895

GTD refers to the difference between the condensing temperature and the inlet water temperature.

# COMPRESSORS, CHILLERS & CONDENSERS

## MARINE CONDENSER REPLECMENT PARTS

MODEL NO	REPLACEMENT PART NO		
	CONDENSER HEAD	CONDENSER REAR	GASKET
MHX-602B-4	HEAD0011457	HEAD0021178	GASKE020344
MHX-602D-4	HEAD0011457	HEAD0021178	GASKE020344
MHX-603D-4	HEAD0011457	HEAD0021178	GASKE020344
MHX-604D-4	HEAD0011457	HEAD0021178	GASKE020344
MHX-605D-2	HEAD0011457	HEAD0021178	GASKE020344
MHX-606D-2	HEAD0011457	HEAD0021178	GASKE020344
MHX-805A-2	HEAD0021323	HEAD0021330	GASKE020351
MHX-806A-2	HEAD0021323	HEAD0021330	GASKE020351
MHX-808A-2	HEAD0021323	HEAD0021330	GASKE020351
MHX-1005A-2	HEAD0021347	HEAD0021147	GASKE020368
MHX-1006A-2	HEAD0021347	HEAD0021147	GASKE020368
MHX-1008A-2	HEAD0021347	HEAD0021147	GASKE020368
MHX-1205A-2	HEAD0018960	HEAD0021161	GASKE020375
MHX-1206A-2	HEAD0018960	HEAD0021161	GASKE020375
MHX-1208A-1	HEAD0010742	HEAD0010742	GASKE020375
MHX-1208A-2	HEAD0018960	HEAD0021161	GASKE020375
MHX-1210A-1	HEAD0010742	HEAD0010742	GASKE020375
MHX-1405B-2	HEAD0010569	HEAD0011576	GASKE017655
MHX-1406B-2	HEAD0010569	HEAD0011576	GASKE017655
MHX-1408B-2	HEAD0010569	HEAD0011576	GASKE017655
MHX-1410B-1	HEAD0019682 EPOXY	HEAD0021435 EPOXY	OHC141D
MHX-1608B-1	HEAD0021435 EPOXY	HEAD0021435 EPOXY	OHC141D
MHX-1608B-2	HEAD0010711	HEAD0018946	GASKE017781
MHX-1610B-1	HEAD0021435 EPOXY	HEAD0019682 EPOXY	OHC141C

# COMPRESSORS, CHILLERS & CONDENSERS

## EMERSON 703RC UNLOADER VALVE

### APPLICATION

- 3-Way Unloader Valves
- Electrically operated valve for compressor unloading

### FEATURES

- Stainless steel and brass construction
- OEM drop-in replacement

### SPECIFICATIONS

- Maximum working pressure: 500 psig
- MOPD: 300psig
- Drop-in replacement for Copeland part number 510-0212-00

### NOMENCLATURE

Example: 703RBVLC

<b>703RC</b>	<b>VLC</b>
Valve Series	Coil*

NOTE: Valves are shipped without the solenoid coils (VLC = Valve Less Coil).  
See coil section of catalog for information.

### DIMENSIONAL DATA

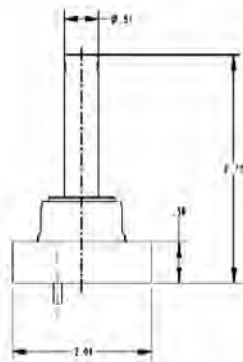

P4602

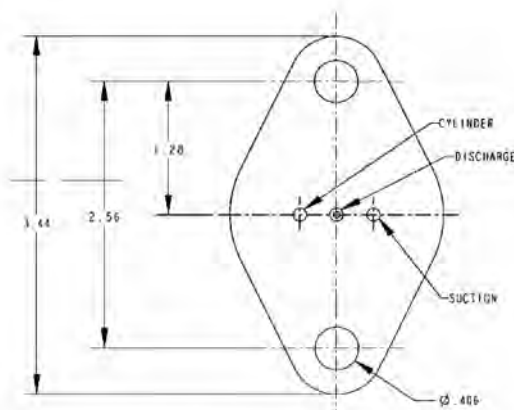

P4602B

NOTE: Dimensions shown are in inches. Fractions (decimal).

NOTE: Coil sold separately.

PCN*	DESCRIPTION
065131**	703RC-001 AMC 120/50/60
065132	703RC-001 AMC 208-240/50-60
065126**	703RC-001 VLC

\*\*Standard Product Offering.

\*Product Code Number.

NOTE: Body gasket not included. Consult compressor manufacturer for body gasket information.